

## END DRIVE

**Low Profile End Drives Conveyors** for all your conveyor applications where space is a premium. We have the latest in technology. We offer various sizes of conveyors featuring below, top side and direct drives. We have a wide variety of belt sizes and types for all your applications including fabric, wire mesh, cleats, timing and plastic chain.

### SPECIFICATIONS

---

**Frames:**

2 7/8" high aluminum extrusion  
2 7/8" high stainless steel

**Conveyor Widths:**

2 1/8" – 100 1/2"

**Drives:**

End – Direct, Top, Bottom mounted

**Live Load Capacity:**

Up to 50 lbs/ft.

### FEATURES

---

- Space saving conveyor
- Design flexibility
- Belts are 1/2" less than frames
- Wide variety of belt sizes and types
- Precision machined conveyor components
- Low profile to work in tight places
- Rollers are machined tapered
- Belts are factory tracked
- Endless belts require less maintenance than metal laced belts
- Conveyors are rated for industrial environments
- Supports are modular design
- Controls are Nema 12 rated to meet factory requirements



### Low Profile End Drives

### APPLICATIONS

---

Transportation  
Accumulation  
Automated Part Feeding Cells  
Feeder Bowl Conveyors  
Sortation  
Indexing  
Part Orientors  
Metering Conveyors  
Assembly Lines  
Work Stations  
Cooling



# End Drive

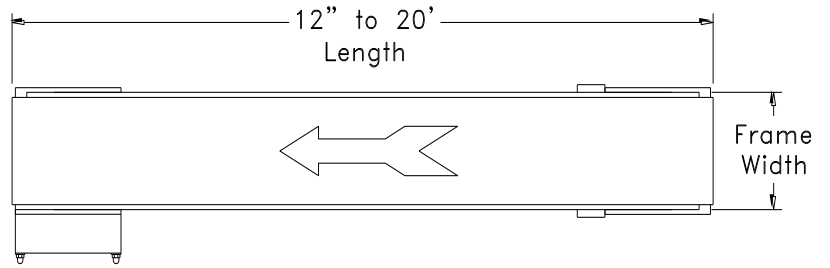
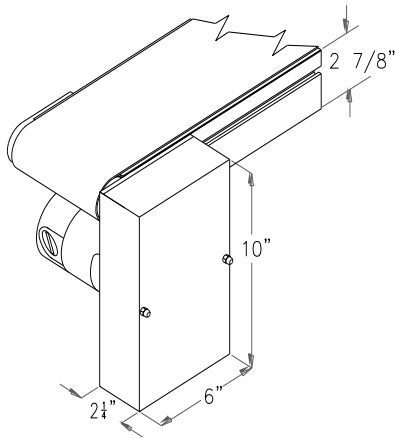

**Plan View**



**Side View**

## Standard Sizes

Frame Width	Belt Width
2 1/8"	1 5/8"
4 1/2"	4"
6 1/2"	6"
8 1/2"	8"
10 1/2"	10"
12 1/2"	12"
14 1/2"	14"
16 1/2"	16"
18 1/2"	18"
20 1/2"	20"
22 1/2"	22"
24 1/2"	24"

